



Technical Specification/Submittal

EA Defender Turnstile

If you want to be 100% sure of reliable site access security then the full-height **EA Defender Turnstile** is the best choice. This device provides complete access control being a physical barrier, subject to the required level of security it can be supplied with either a single, double, or multiple cage. Custom versions are available upon request and are all UK manufactured

Authorised access can be performed by means of access control via RFID card readers or fobs, biometric devices, or remote control. EA Group can offer all of these devices and many more.

Our sturdy design ensures uninterrupted operation for millions of passages. In free access mode, up to 20 pedestrians per minute can go through the turnstile.

This full-height rotor turnstile is hot dip galvanised and can have an additional powder coated finish on request. Our unique design can also as an option have a number stainless steel rods that stop any damage from prolonged use and also can be easily cleaned

Model	EA Defender
Size	1428x1168x2297mm
Input voltage	110-240v AC or 12V DC
Drive motor	Electro-mechanical
Passing speed	upto 30 people/minute
Applicable temperature	-20°C to +70°C
Life time	9 million operations
Finish	Hot dip galansed and powder coated
Operation	Single / Bi-directional
Wight	300-350kg

Technical Specification/Submittal

EA Defender Turnstile

The **EA Defender Turnstile** Is proudly manufactured in the UK and is always in stock

Controlled by

- Access control system
- Manual control

Additional Options

- Manual unlocking in case of unavailable power
- Reader for access control system
- Remote radio controller
- Backup battery 24v
- Protective canopy

Electrical specification

- From an AC source (100-240V), 50/60Hz
- From a DC source 12V

Maximum power consumption 30 W per pass

Width: 1428mm
Length: 1168mm
Height: 2297mm
Weight: 300-350kg

Mechanism: Electro-mechanical
Finish: Hot dip galvanised

Optional Finishes:

- Powder Coated RAL
- Brushed AISI 304
- Brushed SS AISI 316
- Polished SS AISI 304
- Polished SS AISI 316



Additional Options

- Manual unlocking in case of unavailable power
- Reader for access control system
- Remote radio controller
- Backup battery 24v
- Protective canopy

Technical

Dimensions

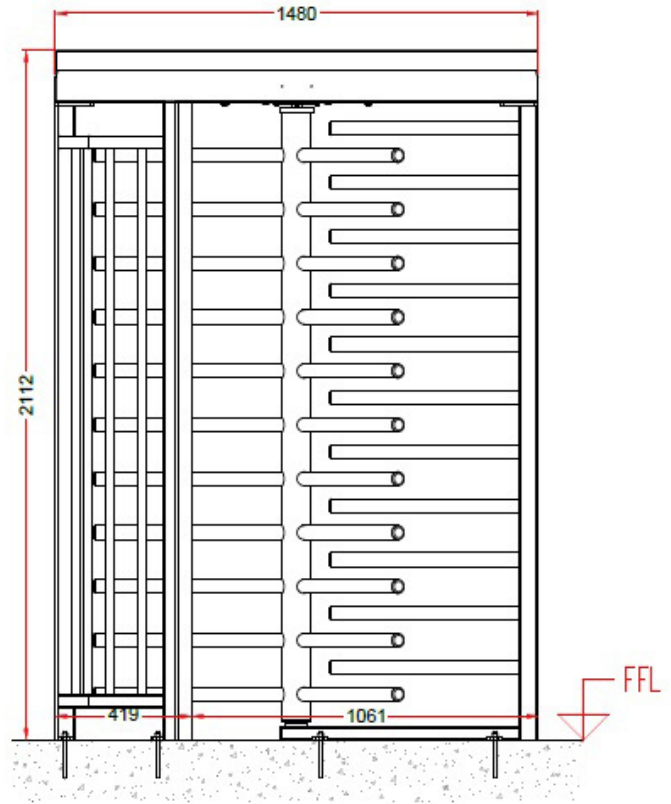
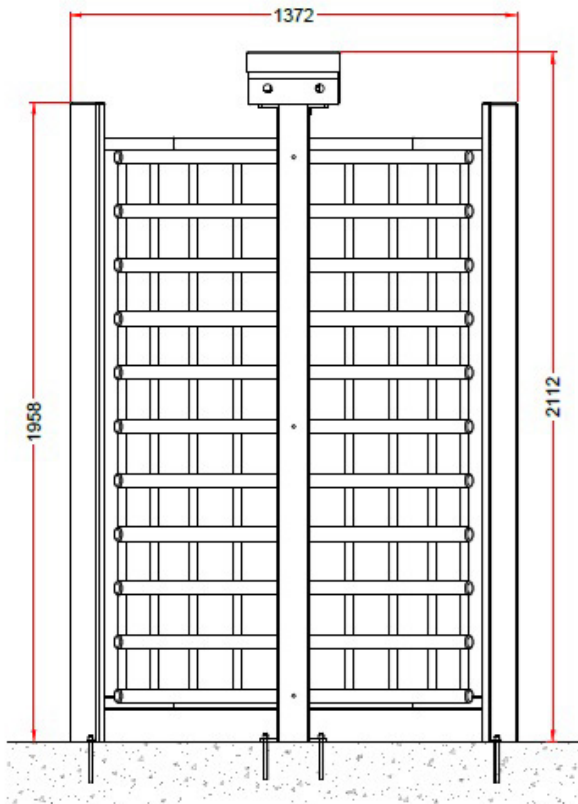
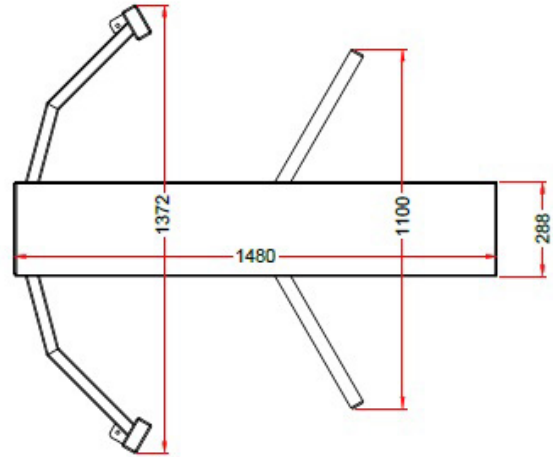



**EA GROUP OFFER A WIDE RANGE OF SECURITY
AND ACCESS CONTROL SOLUTIONS**

Speed Gates, Revolving & Automatic Doors, Automatic
Gates, Access Control, CCTV, Rising & Security
Bollards and Car park & Automatic Vehicle Barriers

We are also able to offer bespoke access solutions: After
Sales / Maintenance & product Support packages Free
quotations

Customised technical drawings and presentations

*Peace of mind, professional service and product
warranty from the UK's leading Access Security
Specialist, Revolving Door, Gate & Barrier
Automation and CCTV installer*

Visit our website:

www.ea-group.co.uk

for further details or telephone our sales
and enquiry desk on

+44 (0)1372 459536

EA Group (UK) Limited

Units 20/21 Bookham Industrial
Park Church Road, Bookham
Surrey, KT23 3EU

Part of the Electro Automation Group of companies

Registered in England: 3094251

VAT No: 994124937



Certificate Number 19313

