



## Technical Specification/Submittal

# EA Swing HG Speed Gate

The **EA Swing HG Speed Gate** is available in single or double lane versions, allowing flexibility to create as many lane entrances as the location/site requires. Matching glass balustrading is available to close or cordon off unused areas.

Access control readers can be easily integrated beneath the EA Swing's slimline glass top design. The design incorporates LED indicators which help guide users through the lane. The EA Swing is also available (Option) with a Stainless-Steel top to accommodate bolt on, face recognition or other biometric reading devices. Lane widths can be configured from 550mm to 900mm (the later to provide easy DDA passage).

**EA Swing HG Speed Gates** can be integrated with both Access Control Units and Fire Alarm Systems, to provide controlled access/egress and or allow free egress in the event of a fire alarm/emergency activation. When integrated with a fire alarm, on fire activation, the leaves open to allow free exit and remain unlocked until the alarm is reset.

Model No	EA-S705HG
Size	1505x135x1012mm
Input voltage	240V
Drive motor	DC 24v brushless motor
Passing speed	23 people/minute
Applicable temperature	-20°C to +70°C
Life time	9 million operations
Material thickness	1.5mm
Swing direction	Single / Bi-directional
Passage widths	550mm wide lane to 900mm wide lane Custom widths also available
Glass height	<b>1500mm - 1800mm</b> in height from FFL

## Technical Specification/Submittal

# EA Swing HG Speed Gate

The **EA Swing HG Speed Gate** is a waist high, very effective speed lane gate, which allows efficient control of staff and visitors alike. Speed Gates remove the pressure from security and reception staff by dealing with the mundane checking of security passes and authorisation. They can block and alert unauthorised entry and tailgating. People who are authorised can pass through simply by presenting a valid access control pass, facial recognition or via other biometric reading device.

The **EA Swing HG Speed Gate** will enhance access efficiency and reduce staffing costs in a reliable and consistent manner. When configured in a line, they look stylish, sleek and an attractive access barrier. The stylish appearance harmonises with high traffic flow capability and user safety.

Most Access Control devices can be easily integrated into the speed gate units. Readers can be mounted and hidden beneath the glass tops with visual LED light indicators as well as voice guidance announcements, if required. A Stainless-steel top (option) offers the ability to surface mount other types of biometric and face recognition devices directly on top of the lanes.

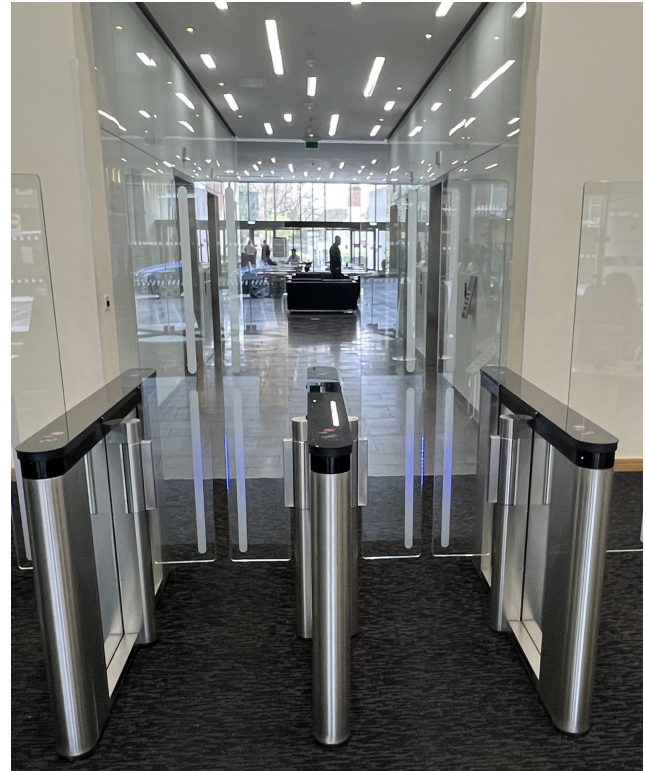

**EA Swing HG Speed Gates** can be configured to operate in a normally closed or normally open mode, in a single or bi direction flow arrangement, with lane width options from 550 to 900 wide. Gate opening/closing times are adjustable but normally open/ close in 0.8 seconds giving a safe passage flow capacity of 30 persons per minute. When integrated with building Fire Alarms, the glass gates can be programmed to open and remain free swinging on fire condition. In the event of a power loss the gates open via a standby battery. Once power is restored the speed gates will automatically run through a re-set cycle and then be ready for normal operation.

**EA Swing HG Speed Gates** come with a standard brushed Stainless-Steel AISI 304 finish. They can also be supplied in polished Stainless Steel or any RAL powder coat colour option. It's pleasing sleek, modern design and the use of high-quality parts and materials makes it one of the most reliable, robust and long-lasting speed gate units available today.

## Technical Specification/Submittal

# Wiring & Layout Details

## 1500mm High

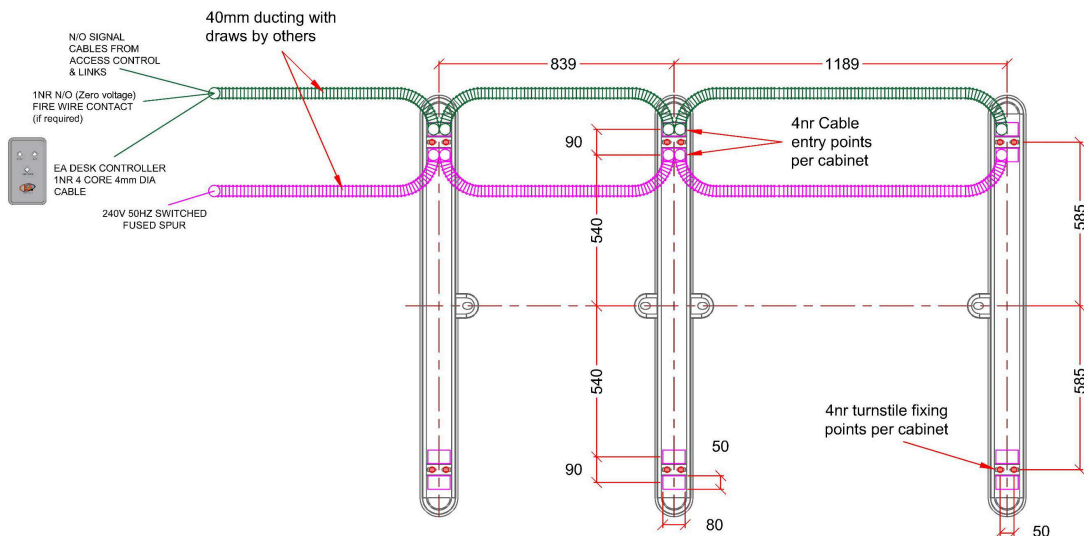
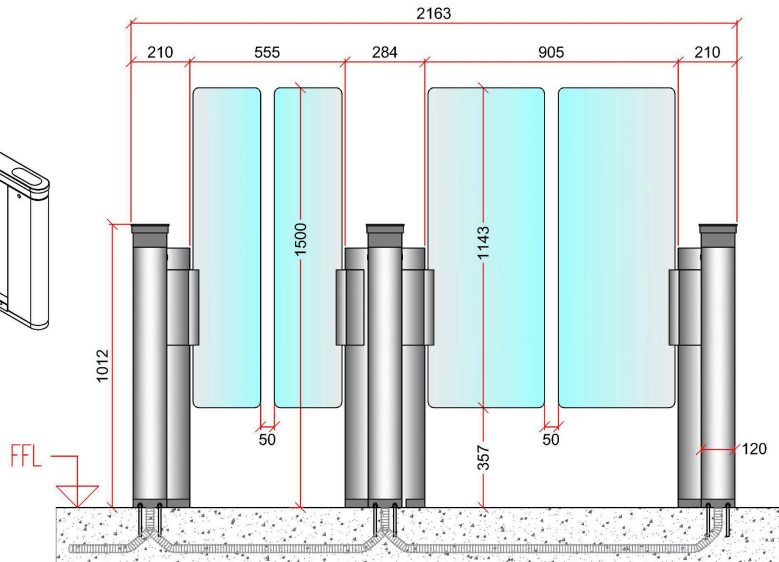
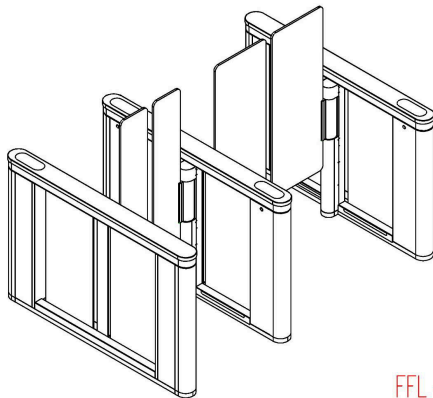
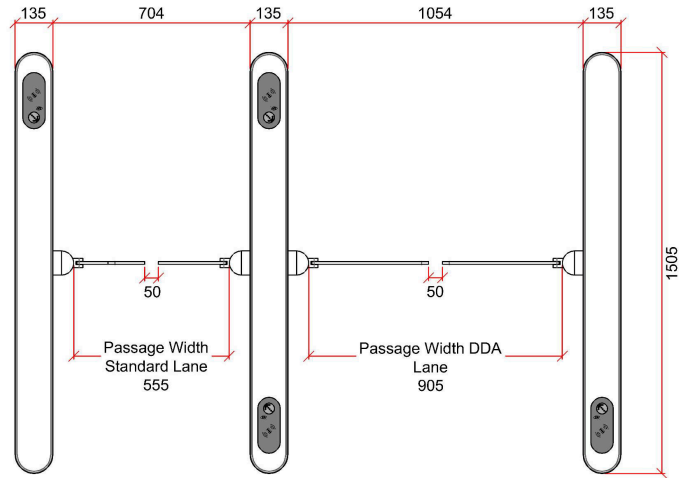

## Technical Specification/Submittal

# Wiring & Layout Details

## 1800mm High

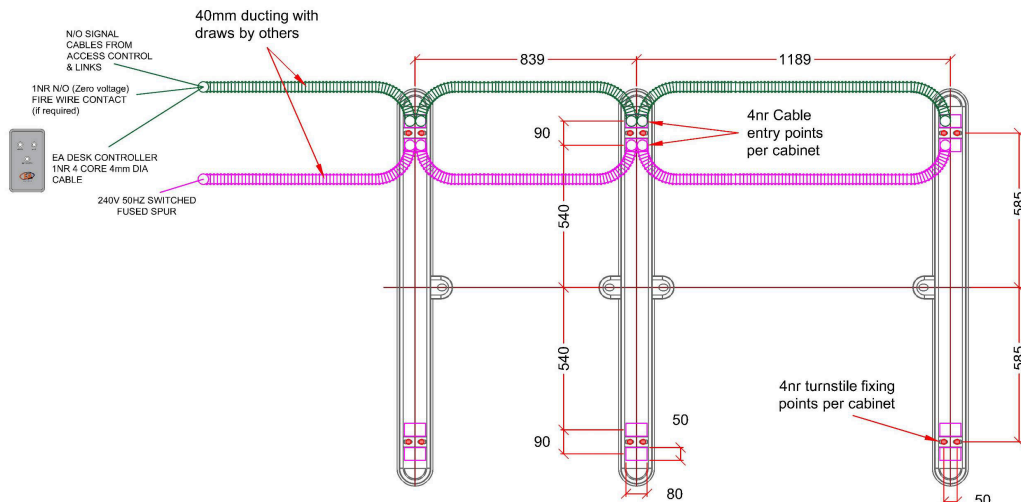
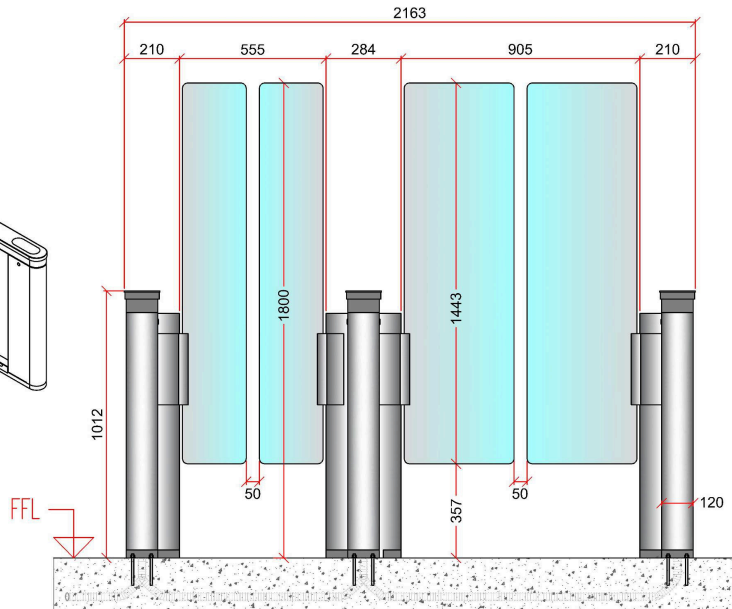
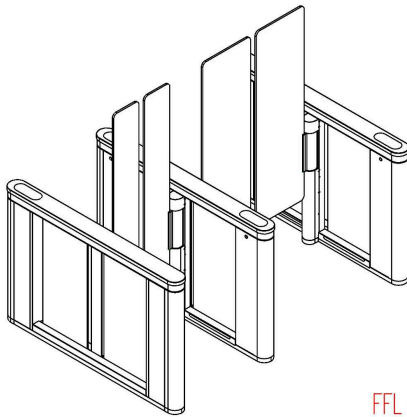
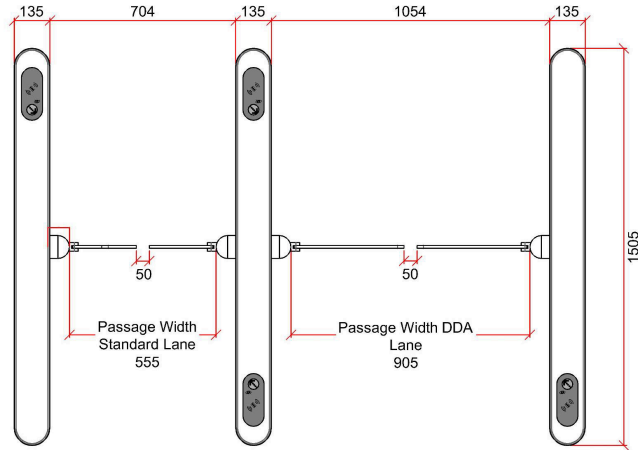



**EA GROUP OFFER A WIDE RANGE OF SECURITY  
AND ACCESS CONTROL SOLUTIONS**

Speed Gates, Revolving & Automatic Doors, Automatic  
Gates, Access Control, CCTV, Rising & Security  
Bollards and Car park & Automatic Vehicle Barriers

**We are also able to offer bespoke access solutions:**

After Sales / Maintenance & product Support  
Free quotations  
Customised technical drawings and presentations

*Peace of mind, professional service and product  
warranty from the UK's leading Access Security  
Specialist, Revolving Door, Gate & Barrier  
Automation and CCTV installer*

Visit our website:

**[www.ea-group.co.uk](http://www.ea-group.co.uk)**

for further details or telephone our  
sales and enquiry desk on

**+44 (0)1372 459536**

**EA Group (UK) Limited**

Units 20/21 Bookham Industrial  
Park Church Road, Bookham  
Surrey, KT23 3EU

Part of the Electro Automation Group of companies

Registered in England: 3094251

VAT No: 994124937



Certificate Number 19313

